

Cerebrospinal Fluid Profile of Amyloid β Peptides in Patients with Alzheimer's Disease Determined by Protein Biochip Technology

Alessia S. Maddalena^a Andreas Papassotiropoulos^a
Charo Gonzalez-Agosti^a Andri Signorell^a Thomas Hegi^b Thomas Pasch^b
Roger M. Nitsch^a Christoph Hock^a

^aDivision of Psychiatry Research and ^bInstitute of Anesthesiology, University of Zürich, Zürich, Switzerland

Key Words

Alzheimer's disease · β -Amyloid · Cerebrospinal fluid · Protein biochip · ELISA

Abstract

Amyloid- β peptides ($A\beta$) are major components of amyloid plaques in the Alzheimer's disease (AD) brain and have been proposed as diagnostic markers in cerebrospinal fluid (CSF). $A\beta$ derived from brain may be processed into fragments before emerging in CSF. Therefore, we determined mass profiles of $A\beta$ peptides in CSF of patients with AD and age-matched healthy control subjects (CTR) by using protein biochip technology. $A\beta$ peptides were captured on the chip surfaces (spots) by the specific monoclonal antibody 6E10 and were then analyzed by integrated surface-enhanced laser desorption and ionization time-of-flight mass spectrometry (SELDI-TOF-MS). We found $A\beta$ species with mean molecular masses at 1,583.3 Da (corresponding to $A\beta_{2-14}$), 2,068.5 Da ($A\beta_{1-17}$), 2,166.4 Da ($A\beta_{1-18}$), 3,676.6 Da ($A\beta_{1-33}$), 3,789.4 Da ($A\beta_{1-34}$), 4,076.9 Da ($A\beta_{1-37}$), 4,134.0 Da ($A\beta_{1-38}$), 4,233.3 Da ($A\beta_{1-39}$), 4,332.4 Da ($A\beta_{1-40}$) and 4,516.8 Da ($A\beta_{1-42}$) in both AD ($n = 24$) and CTR ($n = 24$) subjects. $A\beta_{1-38}$ appeared to be a major $A\beta$ species in human CSF along with $A\beta_{1-40}$. Quantitation

revealed that CSF levels of $A\beta_{1-38}$ were significantly decreased in AD as compared to CTR subjects. The CSF profile of $A\beta$ peptides may be used for diagnostic and therapeutic purposes in clinical studies.

Copyright © 2004 S. Karger AG, Basel

Introduction

β -Amyloid ($A\beta$) deposits, along with neurofibrillary tangles, are the major histopathological hallmarks of Alzheimer's disease (AD). The predominant protein component of $A\beta$ plaques are strongly aggregating peptides with an approximate molecular mass of 4 kDa [1–3]. Whereas $A\beta_{42}$ is the major component of $A\beta$ plaques, $A\beta_{40}$ is mostly found in vascular amyloid of brain blood vessels [4]. Cerebrospinal fluid (CSF) levels of $A\beta_{42}$ measured by ELISA were shown to be lower in AD patients as compared to controls [for a review, see 5], while conflicting results were reported from $A\beta_{40}$ measurements [6–12].

A number of reasons explaining the conflicting data were discussed, including heterogeneity of the patient sample and limitations of the ELISA method used, which do not display the various fragments of peptides captured by the monoclonal antibodies.

KARGER

Fax +41 61 306 12 34
E-Mail karger@karger.ch
www.karger.com

© 2004 S. Karger AG, Basel
1660–2854/04/0015–0231\$21.00/0

Accessible online at:
www.karger.com/ndd

Christoph Hock, MD
Division of Psychiatry Research
Psychiatric University Hospital Zürich, Lenggstrasse 31
CH–8029 Zürich (Switzerland)
Tel. +41 44 384 2271, Fax +41 44 384 2275, E-Mail hock@bli.unizh.ch

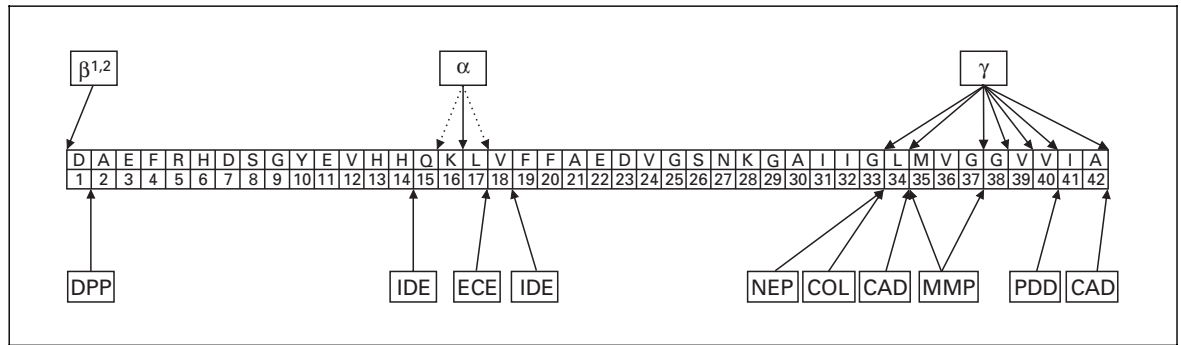

Fig. 1. Potential cleavage sites of A β peptide: secretases and putative proteases. α = Alpha secretase; β = beta secretase (BACE 1 and 2); γ = gamma secretase; DPP = dipeptidyl peptidase; IDE = insulin-degrading enzyme; ECE = endothelin-converting enzyme 1 (ECE-1); NEP = neprilysin; COL = collagenase; MMP = matrix metalloproteinase 9 (MMP-9); CAD = cathepsin D; PDD = peptidyl dipeptidase.

To clarify the patterns of A β peptides present in CSF we determined mass profiles of A β in patients with AD, as well as in age-matched healthy control subjects (CTR) by using a protein biochip technology (SELDI, Ciphergen) [13–17].

Subjects and Methods

Subjects

A diagnosis of probable AD was made according to NINCDS-ADRDA criteria [18] as well as ICD10 [19]. The clinical workup included neuropsychological testing, MRI scans and routine CSF investigations. The mean Mini-Mental State Examination (MMSE) scores were 21 ± 5.8 (SD) in the AD group ($n = 24$). The mean age (SD) was 71.2 ± 9 years; there were 10 females and 14 males. Healthy CTR ($n = 24$) were recruited among cognitively intact patients undergoing spinal anesthesia before surgical intervention. The mean age was 65.7 ± 12 years; there were 8 females and 16 males. The study was approved by the local ethics committee and subjects gave written informed consent prior to the investigation. CSF was obtained by lumbar puncture, aliquoted, immediately frozen at the bedside (-80°C) and freshly thawed prior to the analyses.

Protein Biochip Analysis

Capturing A β peptides from CSF was done on SELDI Protein G-coated (PG20) ProteinChip[®] Arrays (Ciphergen Biosystems, Palo Alto, Calif., USA). Like PS20 ProteinChips, PG20 ProteinChip Arrays contain an epoxy surface which covalently reacts with amine and thiol groups and allows precoupling with recombinant Protein G. The specific monoclonal antibody 6E10 against A β epitope 1–17 (Signet Pathology Systems, Dedham, Mass., USA) was first purified on Protein G columns [ImmunoPure Protein (G) IgG Purification Kit, Pierce Biotechnology, Rockford, Ill., USA] and then added (2 μl of 0.2 mg/ml) on the microspots followed by incubation in a humidity chamber at room temperature for 1 h. Antibody solution was removed and the chip array was washed once in bulk with 8 ml phos-

phate buffer saline (PBS, pH 7.4) containing 0.5% (v/v) Triton X-100 for 10 min, then twice in bulk with 8 ml PBS for 5 min. The spots were coated with 5 μl crude CSF and incubated in a humidity chamber at 4°C overnight. CSF was removed and spots were washed; first in bulk with 8 ml PBS (pH 7.4) containing 0.5% (v/v) Triton X-100 for 10 min, then washed in bulk twice with 8 ml PBS for 5 min, and finally rinsed with 1 mM HEPES buffer. α -Cyano-4-hydroxy cinnamic acid (CHCA) was dissolved in 50% (v/v) acetonitrile, 0.1% (v/v) trifluoroacetic acid. After drying, a 1:5 diluted solution of CHCA was added to the spots (0.5 μl) and mass identification was made by 100 averaged shots in a Ciphergen SELDI Protein Biology System II (PBS II). All data were normalized against a common matrix peak. Signal to noise (S/N) ratios above 2.5 were considered to be sufficient to submit the data to statistical analysis.

Statistical Analysis

Group comparisons were done by nonparametric Mann-Whitney U tests. Statistical significance was assumed at $p < 0.05$.

Results

We found CSF species of A β peptides with mean molecular masses at 1,583.3 Da (corresponding to A β_{2-14}), 2,068.5 Da (A β_{1-17}), 2,166.4 Da (A β_{1-18}), 3,676.6 Da (A β_{1-33}), 3,789.4 Da (A β_{1-34}), 4,076.9 Da (A β_{1-37}), 4,134.0 Da (A β_{1-38}), 4,233.3 Da (A β_{1-39}), 4,332.4 Da (A β_{1-40}) and 4,516.8 Da (A β_{1-42}) in both AD ($n = 24$) and CTR ($n = 24$) subjects (fig. 1a). Mass detection showed high accuracy with minimal intersample deviation and corresponded well to calculated peptide masses (table 1, fig. 1).

A β_{1-38} and A β_{1-40} were the most prominent A β species in CSF and fulfilled the requirement of an S/N ratio over 2.5 for quantitation (fig. 2a, b).

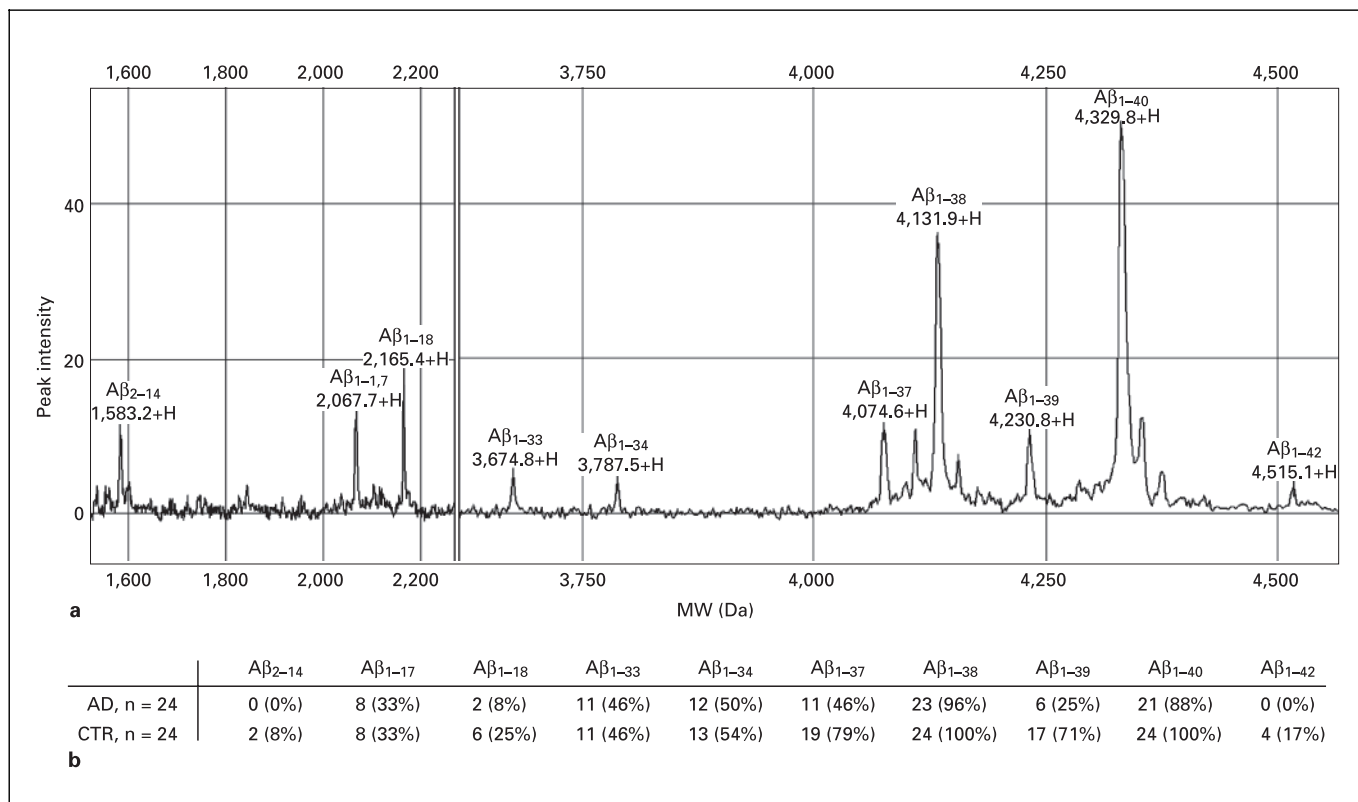

Fig. 2. a CSF profile of Aβ peptides (1 subject) captured by monoclonal antibody 6E10 on a protein biochip. **b** Percentage of Aβ peptide peaks with an S/N ratio higher than 2.5.

Table 1. CSF Aβ peptides captured by monoclonal 6E10 antibody

Aβ peptides	Mean MW observed, Da	SD Da	MW calculated Da	Amino acid sequence
2-14	1,583.3	0.08	1,583.6	AEFRHDSGYEVHH
17	2,068.5	0.69	2,068.2	DAEFRHDSGYEVHHQKL
18	2,166.4	0.65	2,167.3	DAEFRHDSGYEVHHQKLV
33	3,676.6	0.89	3,674.0	DAEFRHDSGYEVHHQKLVVFFAEDVGSNKGAIIG
34	3,789.4	0.85	3,787.2	DAEFRHDSGYEVHHQKLVVFFAEDVGSNKGAIIGL
37	4,076.9	0.98	4,074.5	DAEFRHDSGYEVHHQKLVVFFAEDVGSNKGAIIGLMVG
38	4,134.0	1.00	4,131.6	DAEFRHDSGYEVHHQKLVVFFAEDVGSNKGAIIGLMVGG
39	4,233.3	1.10	4,230.7	DAEFRHDSGYEVHHQKLVVFFAEDVGSNKGAIIGLMVGGV
40	4,332.4	1.00	4,329.9	DAEFRHDSGYEVHHQKLVVFFAEDVGSNKGAIIGLMVGGVV
42	4,516.8	1.63	4,514.1	DAEFRHDSGYEVHHQKLVVFFAEDVGSNKGAIIGLMVGGVVIA

Mean MW with standard deviation (SD) in daltons, calculated peptide MW in daltons and amino acid sequence. Only peaks with an S/N ratio higher than 2.5 were included in the analyses.

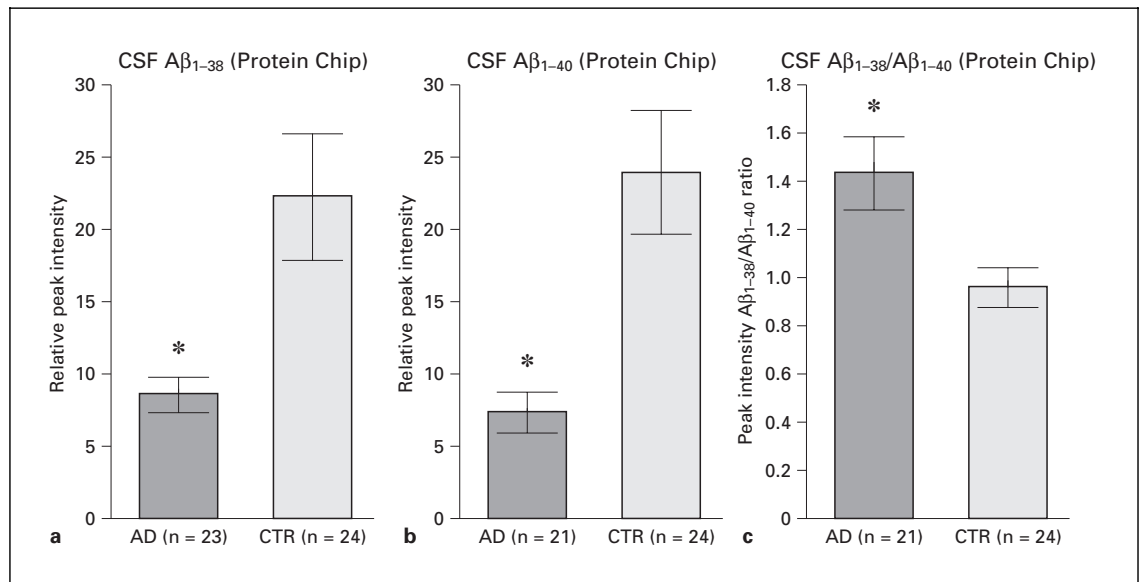

Fig. 3. CSF Aβ₁₋₃₈ (a) and Aβ₁₋₄₀ (b) peak intensity measured on the protein biochip after normalization to a common matrix peak in patients with AD and CTR. * p = 0.001 (a) and * p = 0.000 (b), Mann-Whitney test. Only peaks with an S/N ratio higher than 2.5 were included in calculations. c Mean peak intensity Aβ₁₋₃₈/Aβ₁₋₄₀ ratio in CSF of patients with AD and CTR. * p < 0.01, Mann-Whitney U test.

The mean peak intensity corresponding to Aβ₁₋₃₈ [mean molecular weight (MW) 4,134 Da] was lower in CSF of AD patients (mean 8.65 ± 1.12 SE, n = 23), as compared to CTR (22.28 ± 4.25, n = 24; p < 0.01, Mann-Whitney U test) (fig. 3a). Similarly, the mean peak intensity corresponding to Aβ₁₋₄₀ (mean MW 4,332.4 Da) was lower in CSF of AD patients (mean 7.55 ± 1.18 SE, n = 21) as compared to CTR (23.98 ± 4.25, n = 24; p < 0.01, Mann-Whitney U test) (fig. 3b).

The mean peak intensity of the Aβ₁₋₃₈/Aβ₁₋₄₀ ratio was significantly higher in CSF of the AD patients (1.43 ± 0.15 SE, n = 21), as compared to CTR (0.95 ± 0.08, n = 24; p = 0.01, Mann-Whitney U test) (fig. 3c).

Discussion

We have determined mass profiles of Aβ peptides in human CSF by using protein biochip technology. We found Aβ species corresponding to Aβ₁₋₄₀ and Aβ₁₋₄₂ (4,333.5 and 4,517.7 Da, respectively), and additionally detected Aβ species corresponding to Aβ₂₋₁₄, Aβ₁₋₁₇, Aβ₁₋₁₈, Aβ₁₋₃₃, Aβ₁₋₃₄, Aβ₁₋₃₇, Aβ₁₋₃₈ and Aβ₁₋₃₉ in both AD patients and CTR subjects. Presence of Aβ species with similar mass profiles was recently reported

in cell culture media, measured by immunoprecipitation-MALDI-TOF mass-spectrometric analysis (IP/MS) [20, 21], immunoprecipitation-HPLC-mass spectrometry [22], as well as by SELDI technology [13–16]. In human CSF, several of the mass peaks found in the present analyses, including Aβ₁₋₃₈, were also identified by MALDI-TOF [6] and SELDI [17]. Thus, protein biochip technology may allow for detection of a heterogeneous population of truncated Aβ peptides in human CSF. The exact origin of the various Aβ species is currently not known; in addition to the action of the APP secretases and endopeptidases, such as IDE and neprilysin (see fig. 1), other yet unidentified proteases may be involved. Interestingly Aβ₁₋₃₈ turned out to be one of the most prominent Aβ peptide in CSF, particularly in AD patients, where it showed an even higher peak intensity than Aβ₁₋₄₀. These results are in line with a recent report of increased Aβ₁₋₃₈ (in percent, relative to total Aβ) in CSF of patients with AD, as well as chronic neuroinflammation [6].

The generation of Aβ₁₋₃₈ peptide is still a matter of discussion. Beher et al. [16] showed that such C-terminally truncated peptides are generated by action of γ-secretase and not by a separate enzyme entity. In a cell culture model, Weggen et al. [23] and De Strooper and König [24] also demonstrated an increase of Aβ₁₋₃₈ peptides and a de-

crease of A β ₁₋₄₂ upon administration of nonsteroidal anti-inflammatory drugs with potential γ -secretase activities.

In conclusion, protein biochip technology may allow for both mass profiling and relative quantitation of A β species in human CSF, and may thus expand the methodological repertoire of diagnostic and therapeutic biomarker research in AD.

References

- 1 Jarrett JT, Berger EP, Lansbury PT Jr: The carboxy terminus of the beta amyloid protein is critical for the seeding of amyloid formation: Implications for the pathogenesis of Alzheimer's disease. *Biochemistry* 1993;32:4693-4697.
- 2 Iwatsubo T, Odaka A, Suzuki N, Mizusawa H, Nukina N, Ihara Y: Visualization of A beta 42(43) and A beta 40 in senile plaques with end-specific A beta monoclonals: Evidence that an initially deposited species is A beta 42(43). *Neuron* 1994;13/1:45-53.
- 3 Gravina SA, Ho L, Eckman CB, et al: Amyloid beta protein (A beta) in Alzheimer's disease brain. Biochemical and immunocytochemical analysis with antibodies specific for forms ending at A beta 40 or A beta 42(43). *J Biol Chem* 1995;270:7013-7016.
- 4 Alonzo NC, Hyman BT, Rebeck GW, Greenberg SM: Progression of cerebral amyloid angiopathy: Accumulation of amyloid-beta40 in affected vessels. *J Neuropathol Exp Neurol* 1998;57:353-359.
- 5 Boss MA: Diagnostic approaches to Alzheimer's disease. *Biochim Biophys Acta* 2000;1502:188-200.
- 6 Wiltfang J, Esselmann H, Bibl M, et al: Highly conserved and disease-specific patterns of carboxyterminally truncated Abeta peptides 1-37/38/39 in addition to 1-40/42 in Alzheimer's disease and in patients with chronic neuroinflammation. *J Neurochem* 2002;81:481-496.
- 7 Shoji M, Kanai M, Matsubara E, Tomidokoro Y, Shizuka M, Ikeda Y, Ikeda M, Harigaya Y, Okamoto K, Hirai S: The levels of cerebrospinal fluid Abeta40 and Abeta42(43) are regulated age-dependently. *Neurobiol Aging* 2001;22/2:209-215.
- 8 Tapiola T, Pirttila T, Mikkonen M, et al: Three-year follow-up of cerebrospinal fluid tau, beta-amyloid 42 and 40 concentrations in Alzheimer's disease. *Neurosci Lett* 2000;280/2:119-122.
- 9 Mehta PD, Pirttila T, Mehta SP, Sersen EA, Aisen PS, Wisniewski HM: Plasma and cerebrospinal fluid levels of amyloid beta proteins 1-40 and 1-42 in Alzheimer disease. *Arch Neurol* 2000;57/1:100-105.
- 10 Fukuyama R, Mizuno T, Mori S, Nakajima K, Fushiki S, Yanagisawa K: Age-dependent change in the levels of Abeta40 and Abeta42 in cerebrospinal fluid from control subjects, and a decrease in the ratio of Abeta42 to Abeta40 level in cerebrospinal fluid from Alzheimer's disease patients. *Eur Neurol* 2000;43/3:155-160.
- 11 Jensen M, Schroder J, Blomberg M, Engvall B, Pantel J, Ida N, Basun H, Wahlund LO, Werle E, Jauss M, Beyreuther K, Lannfelt L, Hartmann T: Cerebrospinal fluid A beta42 is increased early in sporadic Alzheimer's disease and declines with disease progression. *Ann Neurol* 1999;45:504-511.
- 12 Kanai M, Matsubara E, Isoe K, Urakami K, Nakashima K, Arai H, Sasaki H, Abe K, Iwatsubo T, Kosaka T, Watanabe M, Tomidokoro Y, Shizuka M, Mizushima K, Nakamura T, Igeta Y, Ikeda Y, Amari M, Kawarabayashi T, Ishiguro K, Harigaya Y, Wakabayashi K, Okamoto K, Hirai S, Shoji M: Longitudinal study of cerebrospinal fluid levels of tau, A beta 1-40, and A beta 1-42(43) in Alzheimer's disease: A study in Japan. *Ann Neurol* 1998;44/1:17-26.
- 13 Davies H, Lomas L, Austen B: Profiling of amyloid beta peptide variants using SELDI Protein Chip arrays. *Biotechniques* 1999;27:1258-1261.
- 14 Frears ER, Stephens DJ, Walters CE, Davies H, Austen BM: The role of cholesterol in the biosynthesis of beta-amyloid. *Neuroreport* 1999;10:1699-1705.
- 15 Austen BM, Frears ER, Davies H: The use of seldi proteinchip arrays to monitor production of Alzheimer's betaamyloid in transfected cells. *J Pept Sci* 2000;6:459-469.
- 16 Behr D, Wrigley JD, Owens AP, Shearman MS: Generation of C-terminally truncated amyloid-beta peptides is dependent on gamma-secretase activity. *J Neurochem* 2002;82:563-575.
- 17 Lewczuk P, Esselmann H, Meyer M, Wollscheid V, Neumann M, Otto M, Maler JM, Ruther E, Kornhuber J, Wiltfang J: The amyloid-beta (Abeta) peptide pattern in cerebrospinal fluid in Alzheimer's disease: Evidence of a novel carboxyterminally elongated Abeta peptide. *Rapid Commun Mass Spectrom* 2003;17:1291-1296.
- 18 McKhann G, Drachman D, Folstein M, Katzman R, Price D, Stadlan EM: Clinical diagnosis of Alzheimer's disease: Report of the NINCDS-ADRDA Work Group under the auspices of Department of Health and Human Services Task Force on Alzheimer's Disease. *Neurology* 1984;34:939-944.
- 19 World Health Organization G: ICD-10: The International Statistical Classification of Diseases and Related Health Problems, 10th revision. Geneva, World Health Organization, 1993.
- 20 Wang R, Sweeney D, Gandy SE, Sisodia SS: The profile of soluble amyloid beta protein in cultured cell media. Detection and quantification of amyloid beta protein and variants by immunoprecipitation-mass spectrometry. *J Biol Chem* 1996;271:31894-31902.
- 21 Kametani F, Nakamura Y, Tanaka K, Hashimoto R, Takeda M: Semiquantitative analysis of amyloid beta peptides using a combination of immunoprecipitation and matrix-assisted laser desorption ionization/time-of-flight-mass spectrometry. *Anal Biochem* 1999;275/2:262-265.
- 22 Clarke NJ, Tomlinson AJ, Ohyagi Y, Younkinn S, Naylor S: Detection and quantitation of cellularly derived amyloid beta peptides by immunoprecipitation-HPLC-MS. *FEBS Lett* 1998;430:419-423.
- 23 Weggen S, Eriksen JL, Das P, et al: A subset of NSAIDs lower amyloidogenic Abeta42 independently of cyclooxygenase activity. *Nature* 2001;414:212-216.
- 24 De Strooper B, Konig G: An inflammatory drug prospect. *Nature* 2001;414:159-160.

Acknowledgments

We thank Lee Lomas and Pia Nybom for technical support and installation of the SELDI protein biochip system (CIPHERGEN), Andrea Walter, Estelle Obrist, Christin Wilde and Esmeralda Garcia for expert technical assistance, and Jay Tracy for editing the manuscript. This work was supported by NCCR on Neuronal Plasticity and Repair, and the European Union under the programme 'Quality of Life and Management of Living Resources', Key Action 3 'The Cell Factory', Contract No. QLK3-CT-2001-02362.